

## Mounting instructions

To achieve the best possible service life and safety from the gas spring, the instructions below must be followed. The gas spring is intended for use in tool and machine applications.

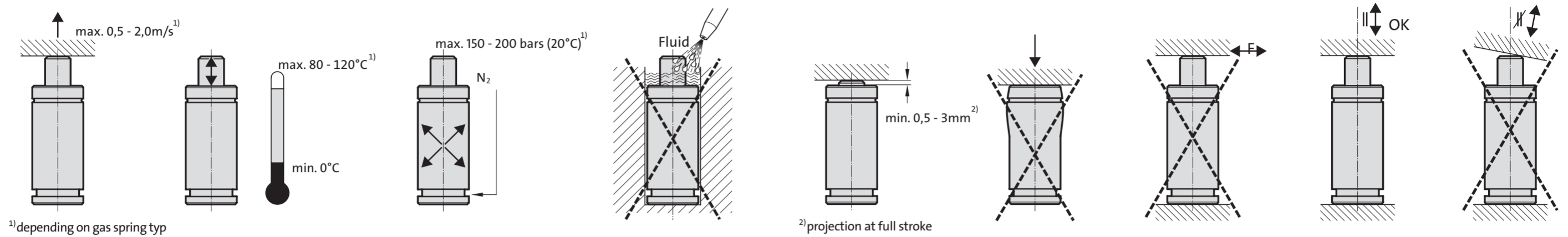

<sup>1)</sup>depending on gas spring typ

<sup>2)</sup>projection at full stroke

- Secure the gas spring to the tool/machine whenever possible, using the threaded hole(s) in the base of the gas spring or a suitable flange.
- The threaded hole in the piston rod top should not be used for mounting purposes. It is only to be used when servicing the gas spring.
- Never install a gas spring in such a way that the piston rod can be released suddenly from the compressed position as internal damage to the gas spring can result.
- Make sure the gas spring is mounted parallel to the direction of the compression stroke.
- Ensure the contact surface of the piston rod top is perpendicular to the direction of the compression stroke and is sufficiently hard.
- The gas spring should not be subjected to the side loads.
- Protect the piston rod against mechanical damage and contact with fluids.
- We do not recommend the last 5 mm or 10 % of the nominal stroke be utilised.
- The maximum charging pressure (at 20°C) must not be exceeded as it may effect the safety of the product.
- Exceeding the gas spring's recommended operating temperature will shorten the service life of the gas spring.
- The entire contact surface of the piston rod / piston should be used.
- Do not remove the adapter base plate 2480.00./2497.00.20. from spring until all gas pressure has been discharged.

## Examples of installation

Examples of gas spring installation options are shown below. See the FIBRO Standard Parts catalogue for further information on installation.

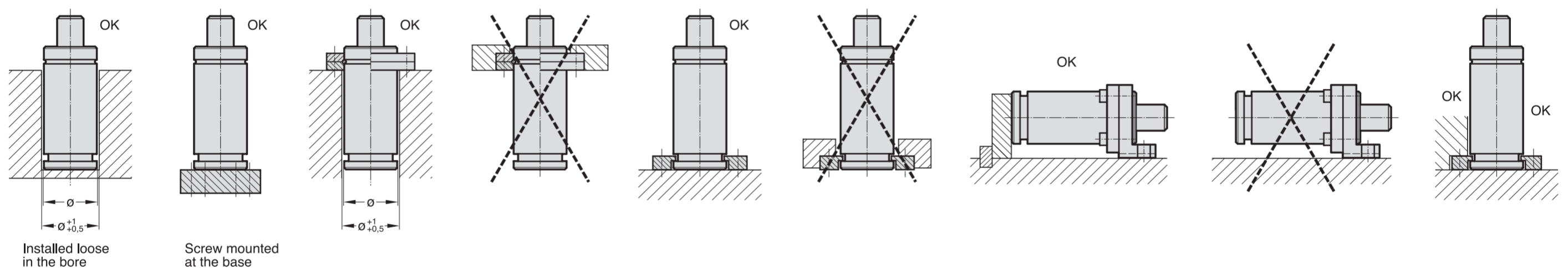

### Service information

If correctly installed and used, the following minimum gas spring service intervals can be expected. Stroke lengths up to and including 50 mm: 1 million strokes. Stroke lengths above 50 mm: 100,000 stroke metres. We recommend the gas spring to be replaced after 2 million strokes. The gas springs are fully serviceable<sup>1)</sup>. To service a gas spring, repair kits and tool kits are available. Service instructions are included with every repair kit. Gas springs must be checked for secure fitting every time there is maintenance work.

### Caution

Only specially trained personnel with a good knowledge of the products should service the gas spring. Mistakes made during assembly and charging may impinge on safety and/or detrimentally affect the service-life of the gas spring. Do not modify the product in any way.

FIBRO is not liable if fittings that are not original FIBRO fittings or fastening, accessory, and attachment parts that are not released by FIBRO are used.

For more information see the FIBRO Gas spring catalogue, or contact your local distributor.

<sup>1)</sup> For Gas Springs that cannot be repaired, see our catalogue Standard Parts.

**Basic information (Exact values of the gas spring types please see the FIBRO Standard Parts catalogue, chapter „Gas Springs“)**

Pressure medium: nitrogen N<sub>2</sub> · Charging pressure 25 - 150 bar at 20°C · Force increase by temp. ±0.3%/°C  
Operating temp. 0- +80°C · Max. allowable piston rod velocity 1.6 m/s